

Remarks

Plixus MM Display

- material : LCM Cover + LCM Support : PC/ABS UL94v0 black
- LCM Backplate : stainless steel AISI 304 . E = 1mm
- finishing : LCM cover : Painting : Pantone Black C
- Textured TC - 11020

Plixus MM Module

- material : Bottom cover : PC/ABS
- Top cover : die cast Zamak 3
- Finishing : Bottom Cover : Painting : textured Pantone Black C
- Top cover : Aluminium coloured paint

Dimension :

- * module size (upright display position) : (WxHxD) 330 x 208 x 155mm
- * module size (horizontal display position) : (WxHxD) 330 x 40 x 235mm

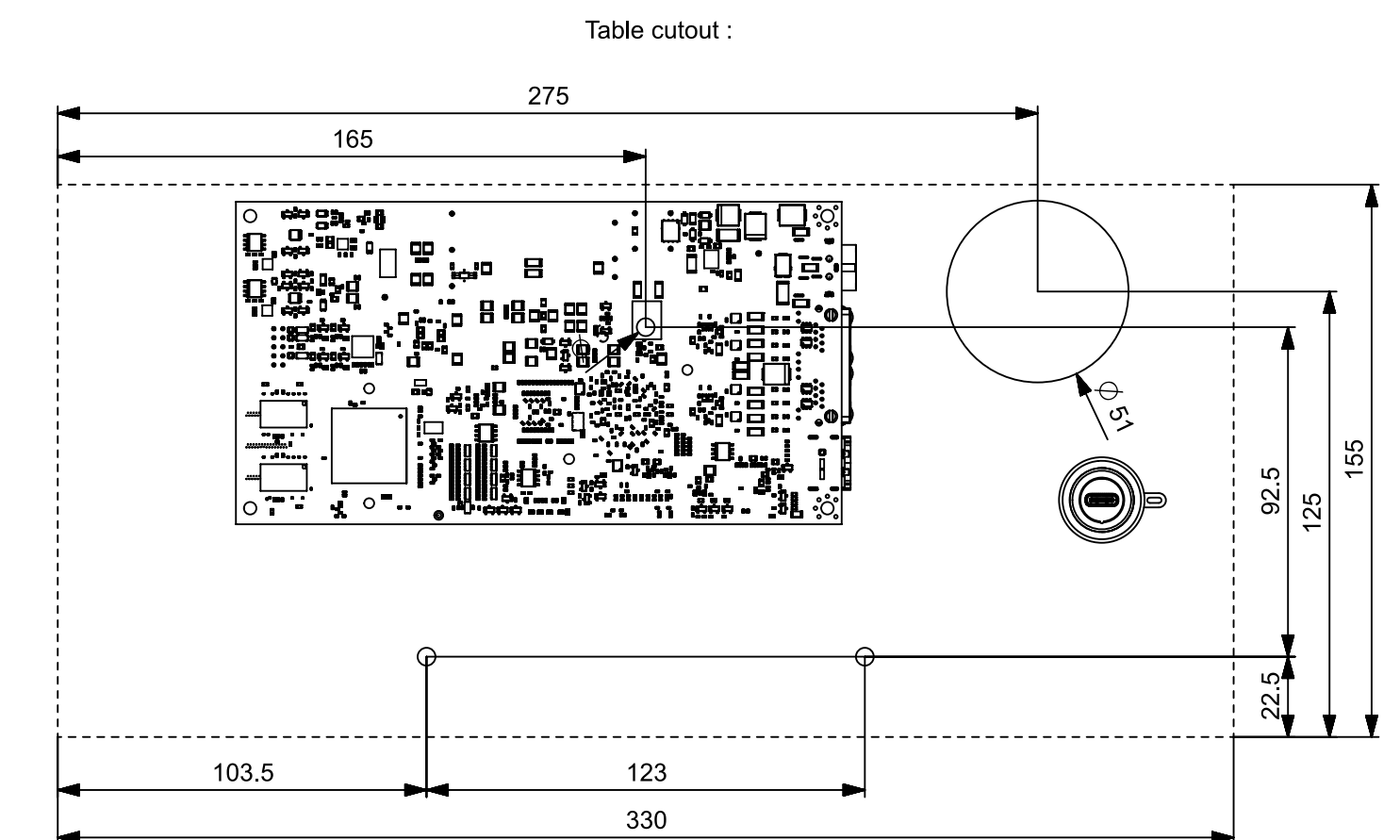
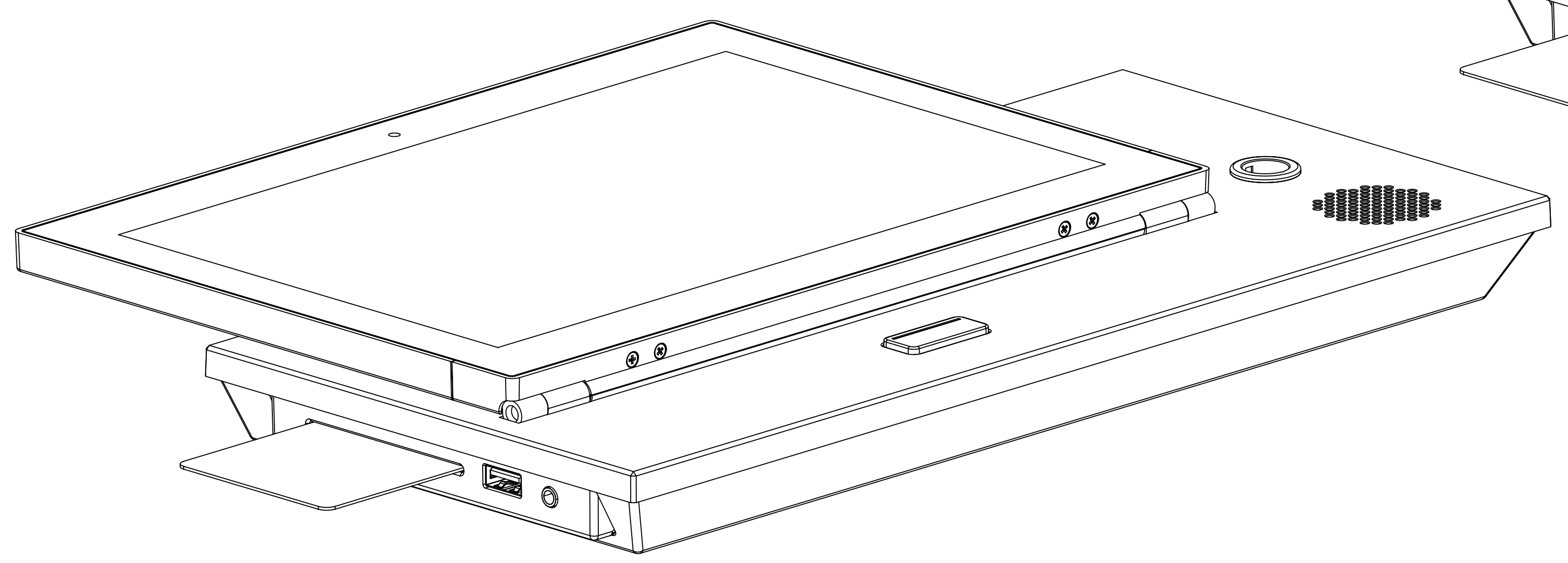
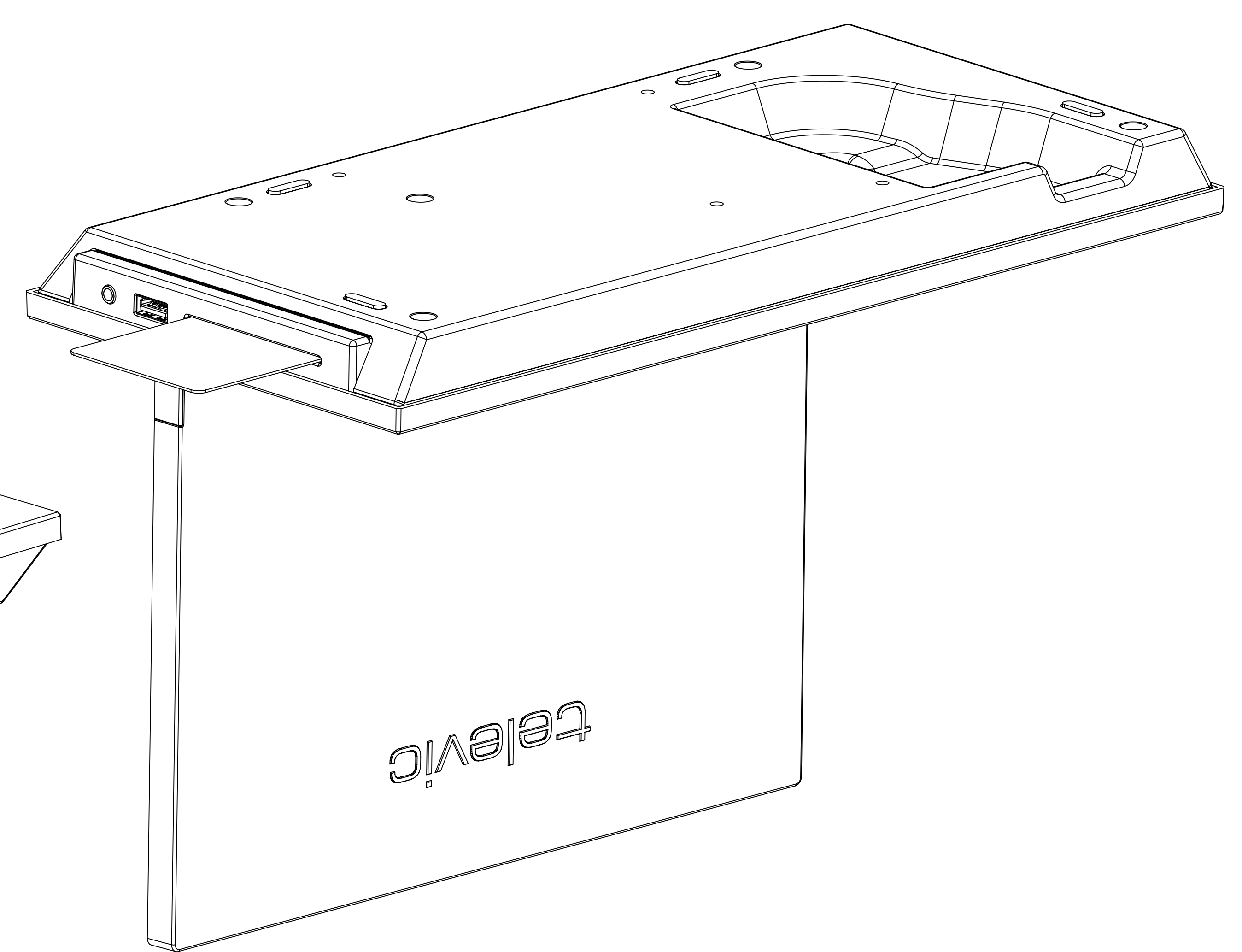
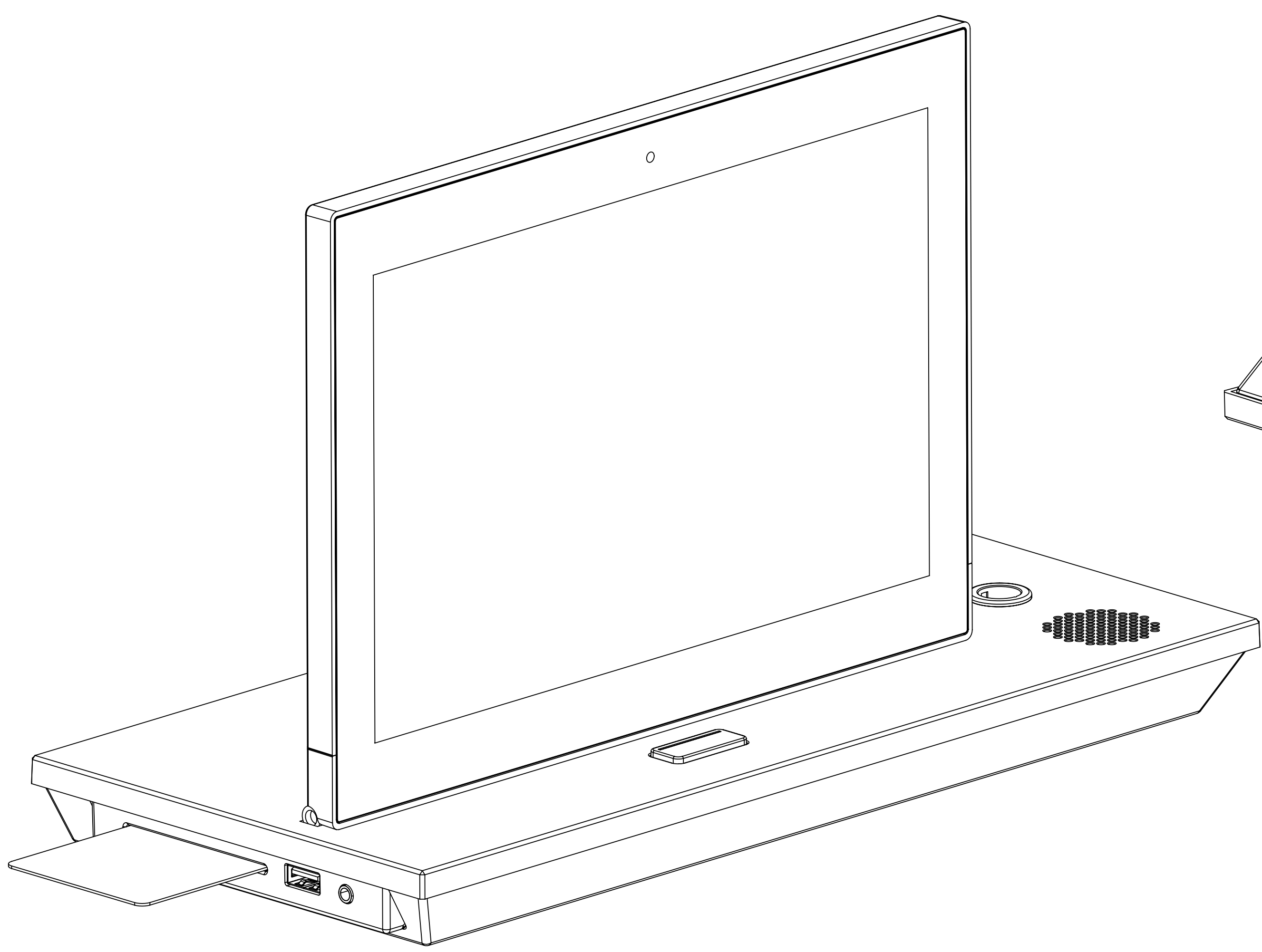
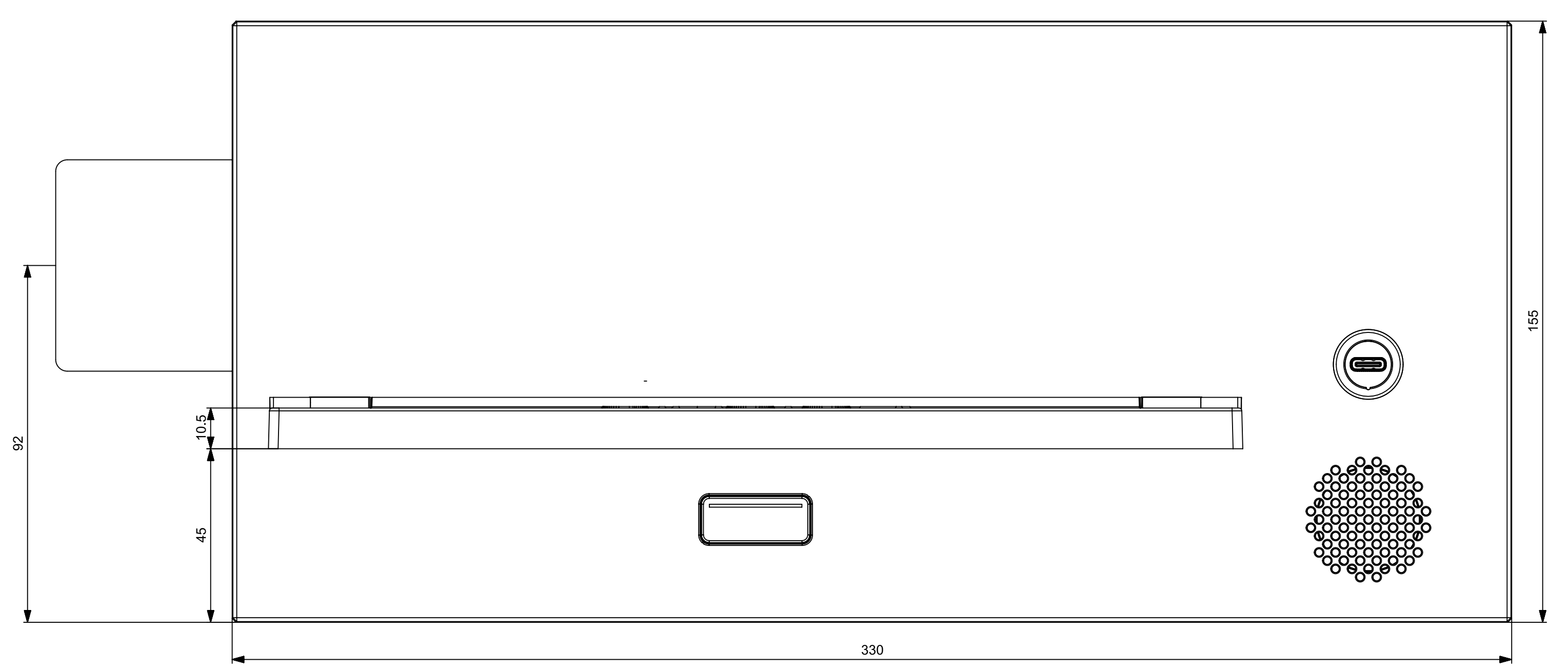

SCALE 1:2

Rev	Author	Date	Description
001	2101023	21/08/2005	Original drawing - based on 71.98.2005
002	2101023	21/08/2005	Revised drawing - based on 71.98.2005

Linear tolerances	Surface roughness	Shape and positioning tolerances	Form tolerances	Finishing
See detailed drawings	See detailed drawings	See detailed drawings	See detailed drawings	See remarks

Drawing name		Material	
10" UNIT PLIXUS T/MM		See remarks	

Name	Date	Drawing number	Sheet
71.98.2005_M07_2D_0.01	21/08/2005	71.98.2005_M07_2D_0.01	1 of 1

telaviv conference

All rights reserved. No part of this concept may be reproduced in any form or by any means without the prior written permission of Telaviv.