

Remarks

**Plixus MM Display :**

- material : LCM Cover + LCM Support : PC/ABS UL94v0 black
- LCM Backplate : stainless steel AISI 304 . E = 1mm
- finishing : LCM cover : Painting : Pantone Black C
- Textured TC - 11020

**Plixus MM Module :**

- material : Bottom cover : PC/ABS
- Top cover : die cast Zamak 3
- Finishing : Bottom Cover : Painting : textured Pantone Black C
- Top cover : Aluminium coloured paint

Dimension :

- \* module size (upright display position) : (WxHxD) 330 x 208 x 155mm
- \* module size (horizontal display position) : (WxHxD) 330 x 40 x 235mm

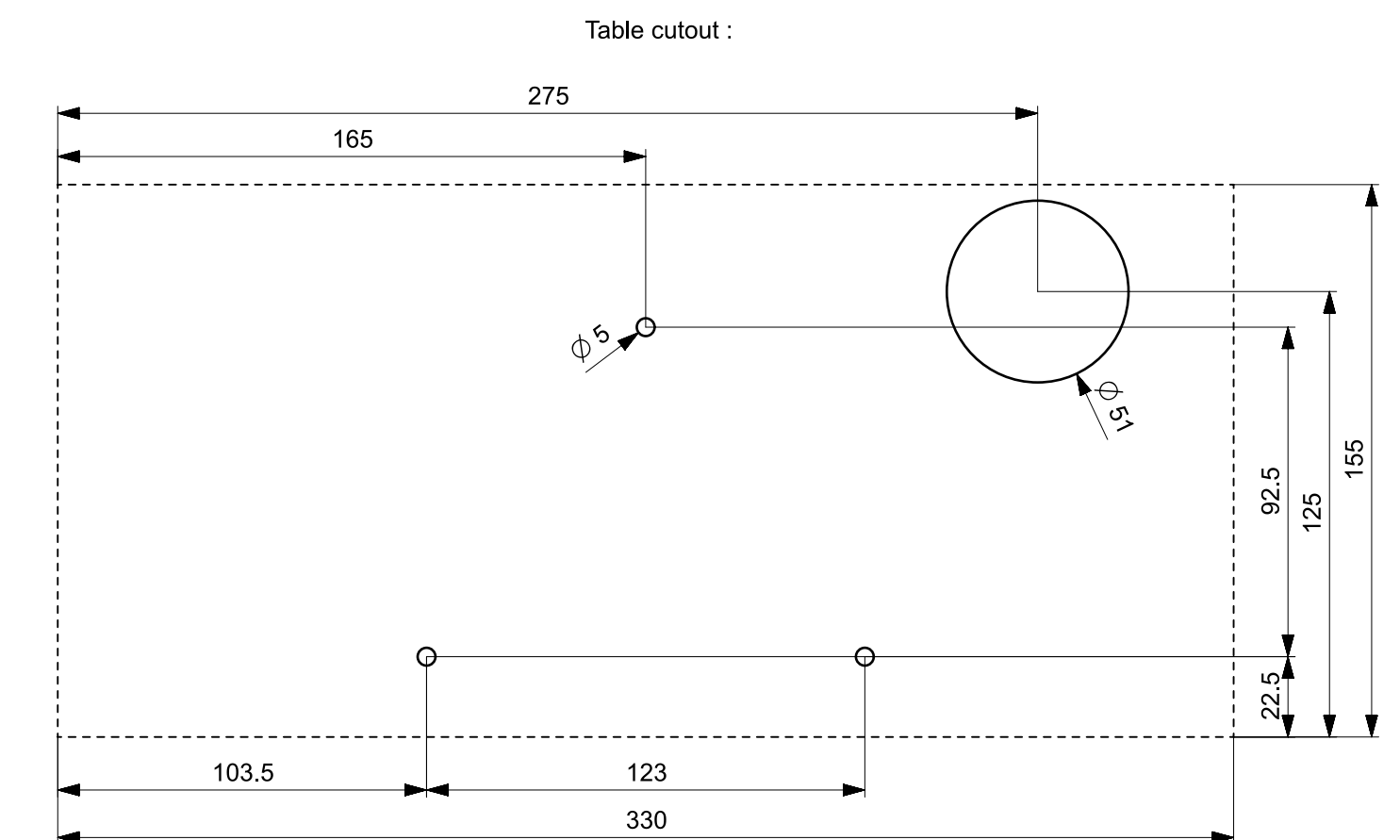
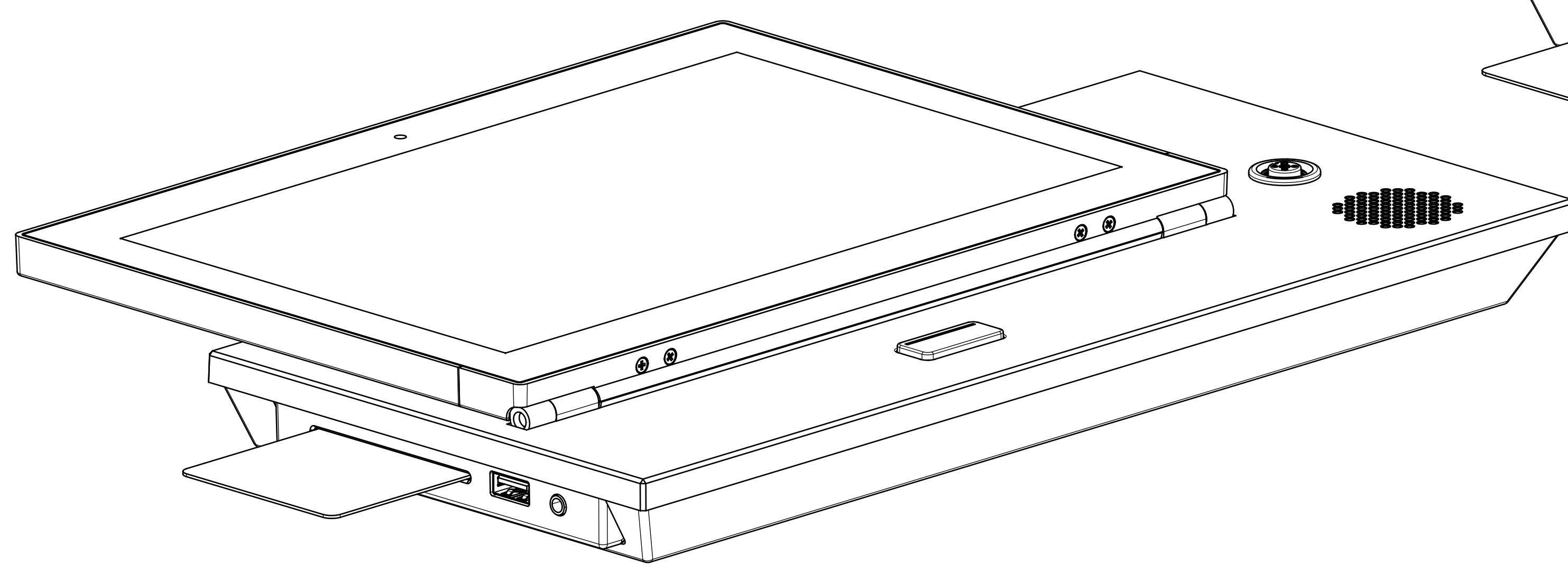
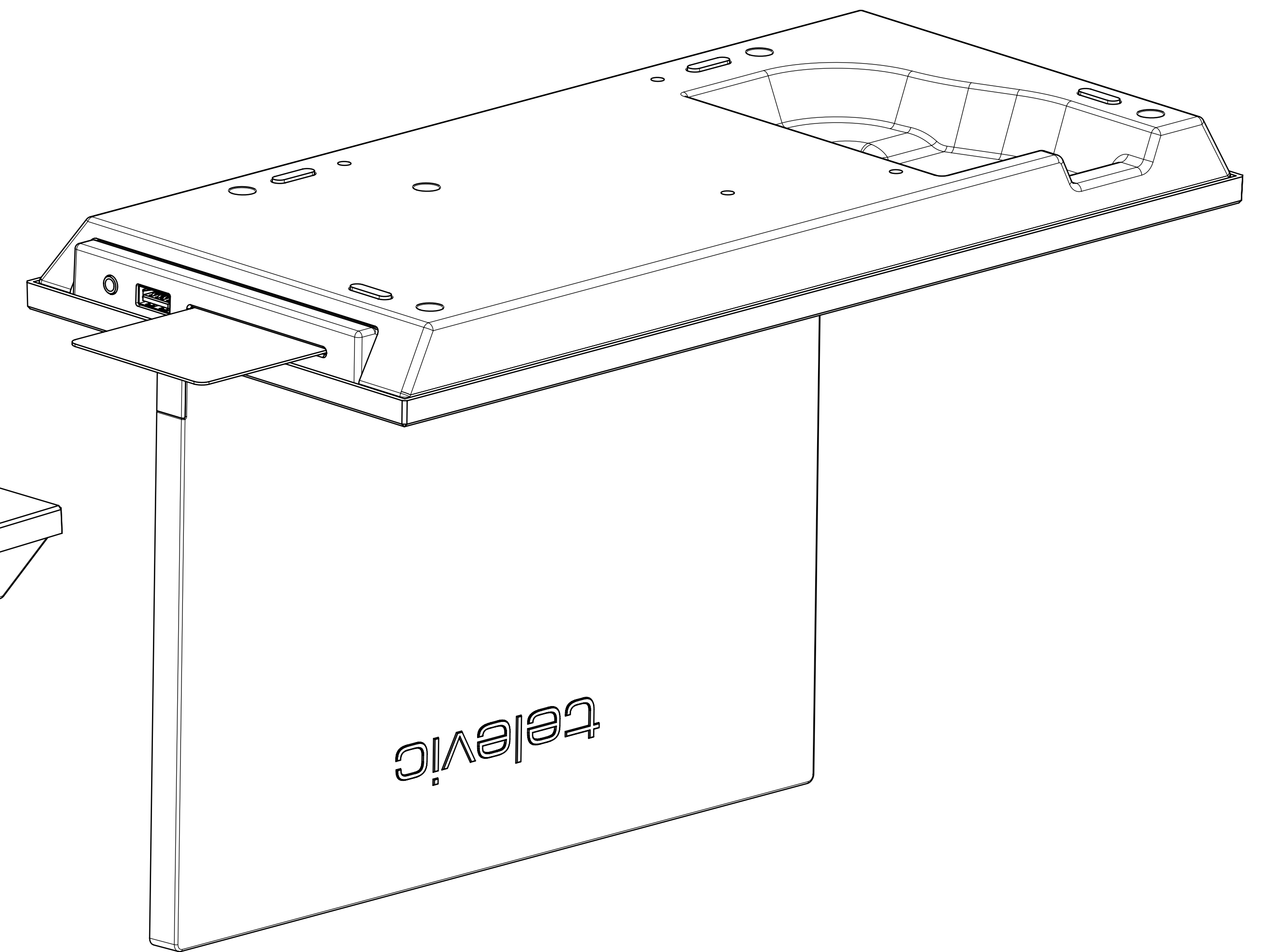
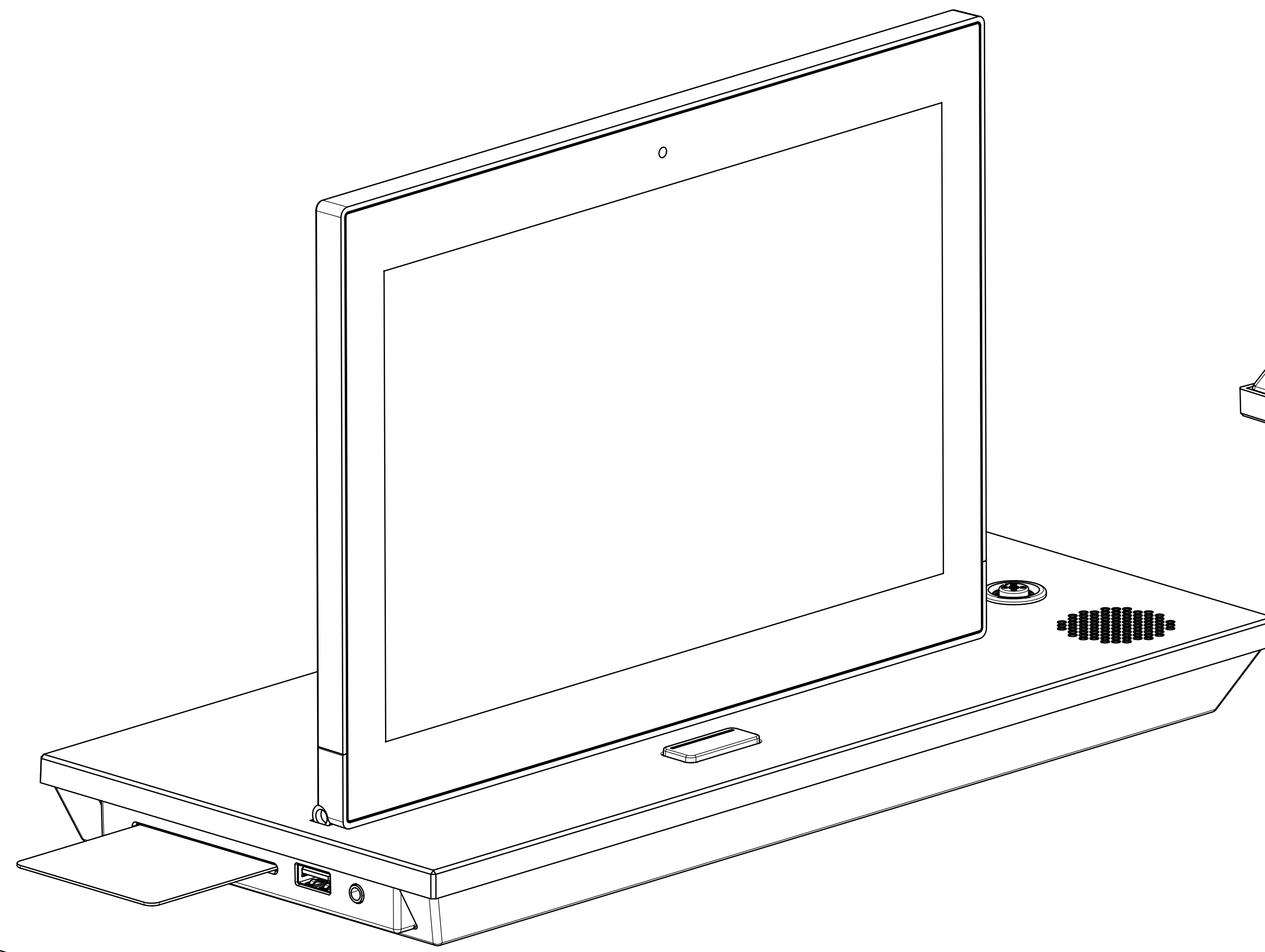
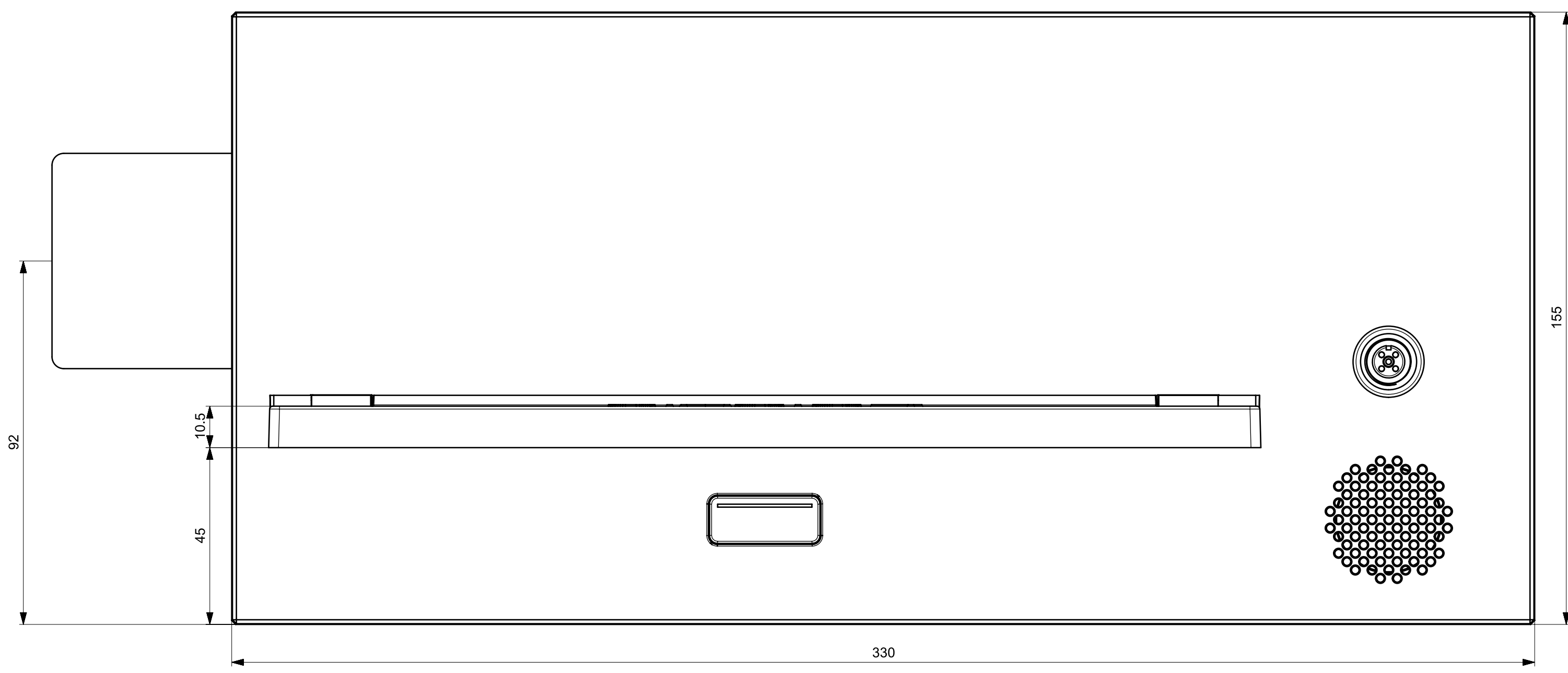

SCALE 1:2

Rev	Description	Date	Author
0.06	Fixed rotation steps removed from display	27/11/20	Arslan
0.05	Replace sheetmetal bottom cover by plastic alternative	27/06/18	Lefteris
0.04	Adjust LCM Cover	28/02/18	Lefteris
0.03	Original drawing - ready for approval	08/02/18	Lefteris
Revision	ECO#	Part name - description	Size
Linear tolerances	Surface roughness	Shape and position tolerances	Form tolerances
See detailed drawings	See detailed drawings	See detailed drawings	See detailed drawings
Drawing name			
<b>10" UNIT PLIXUS T/MM</b>			
Drawing number			
71.98.2003_M07_2D_0.06			
Drawn by	Arslan	27/11/20	Scale: 1:1
Approved by	Arslan	27/11/20	Sheet: 01 of 01
telaviv CONFERENCE			