

Remarks

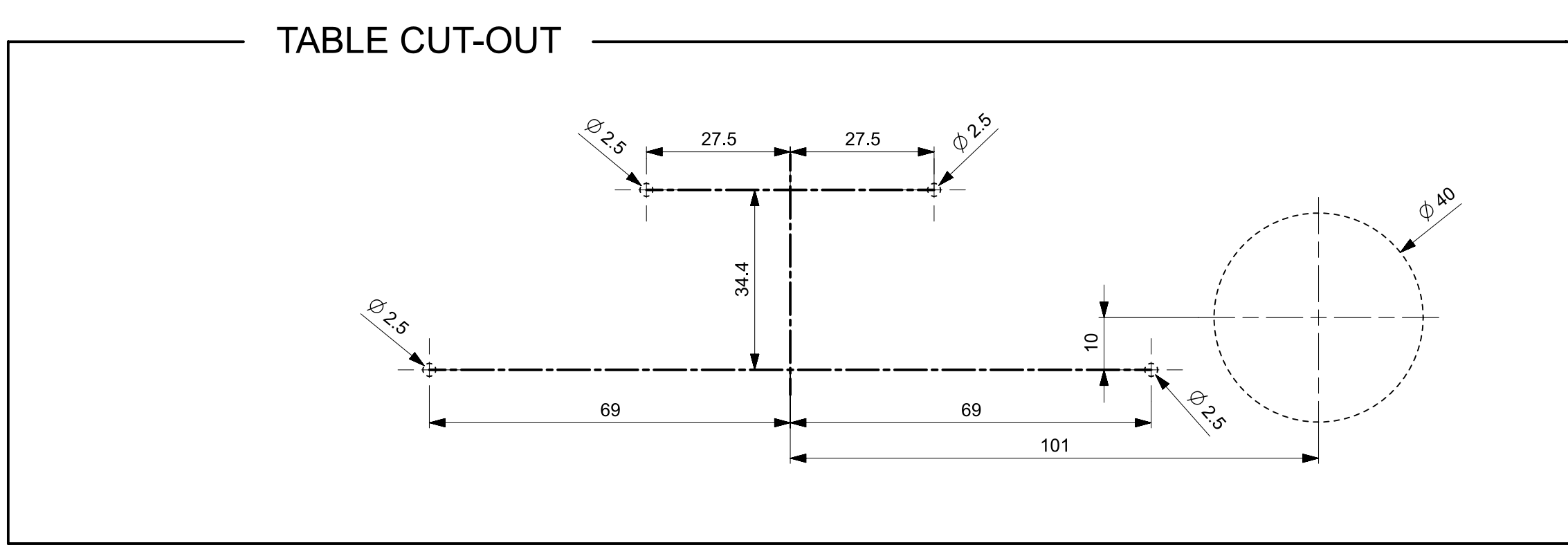
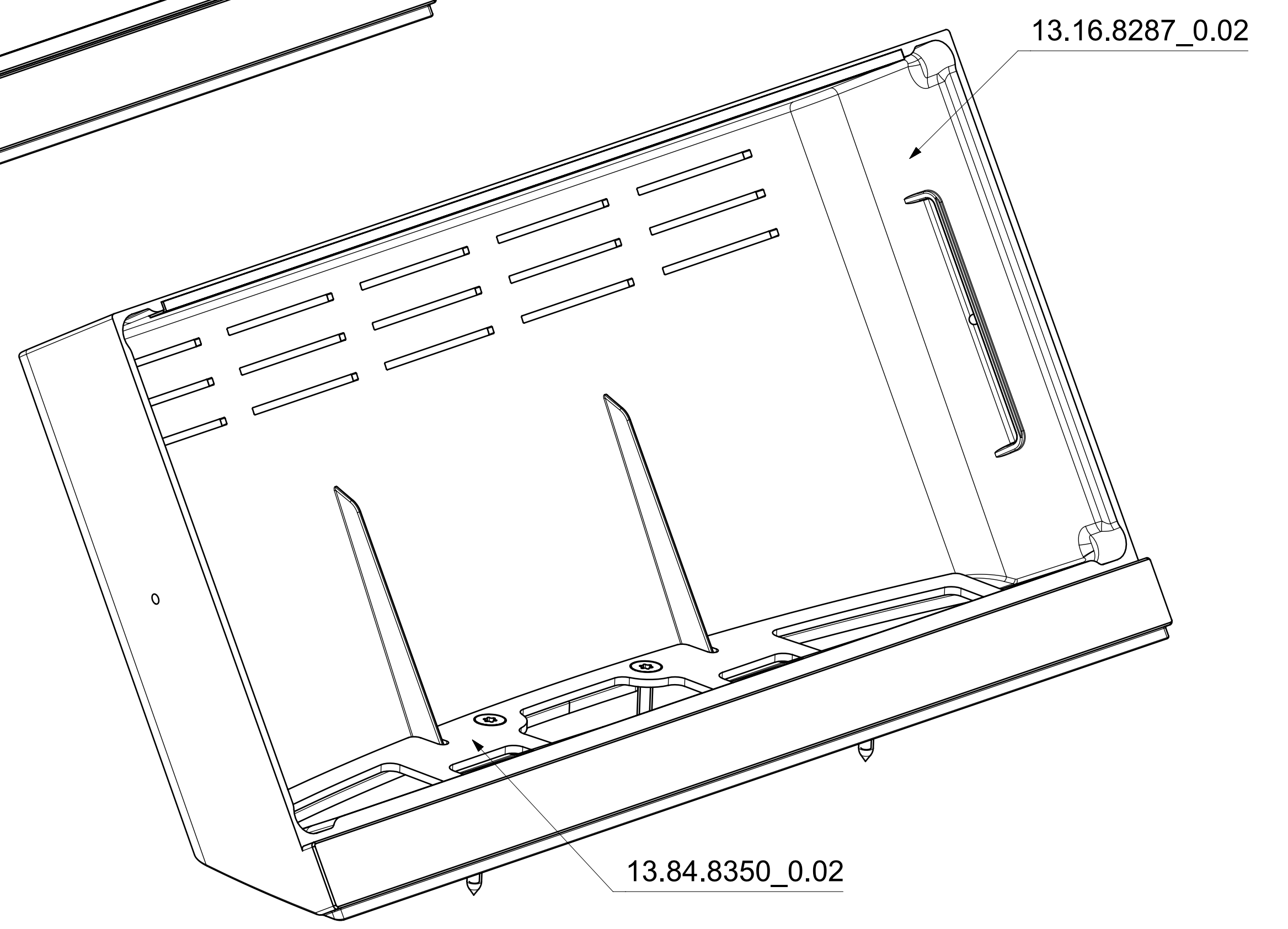
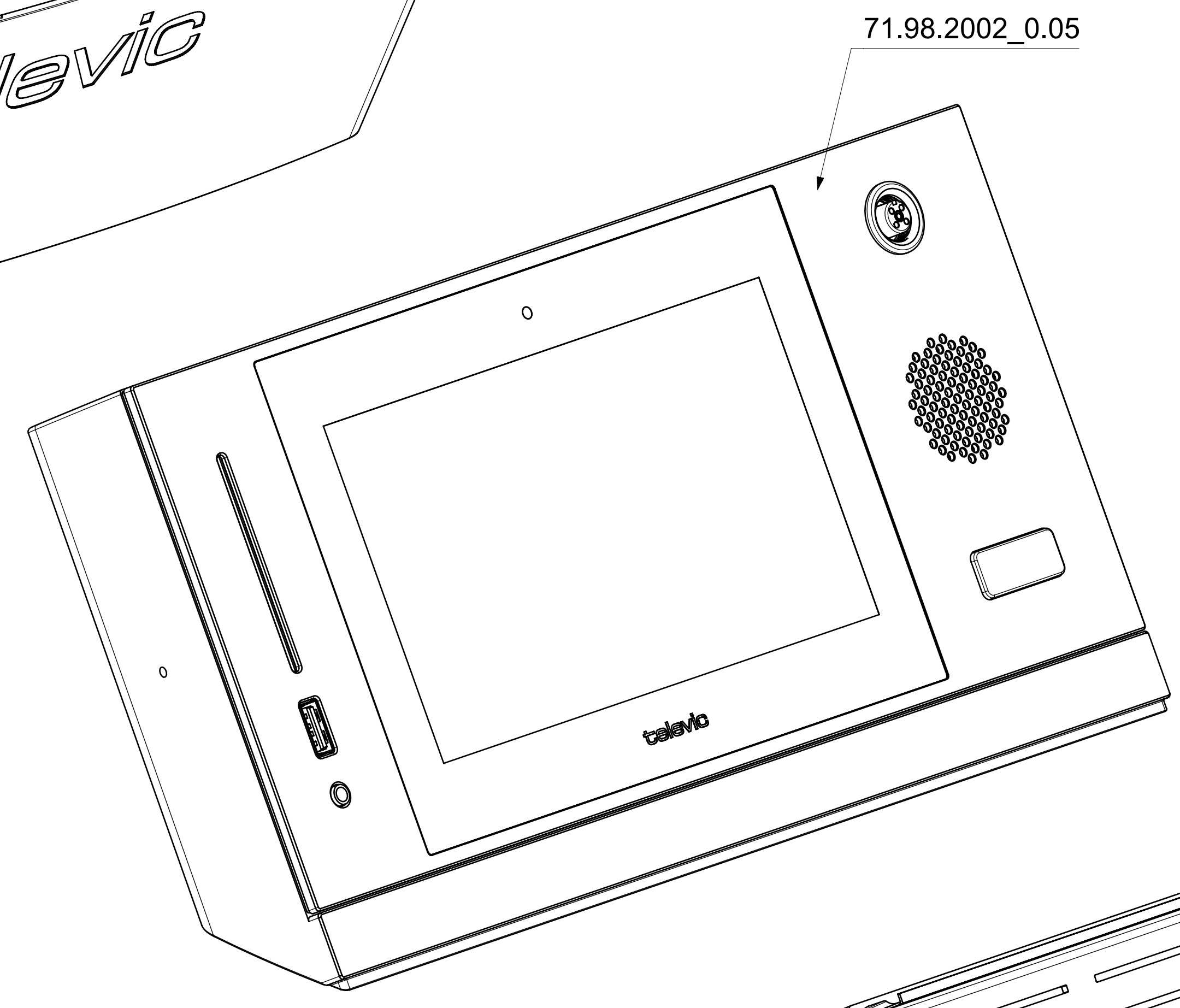
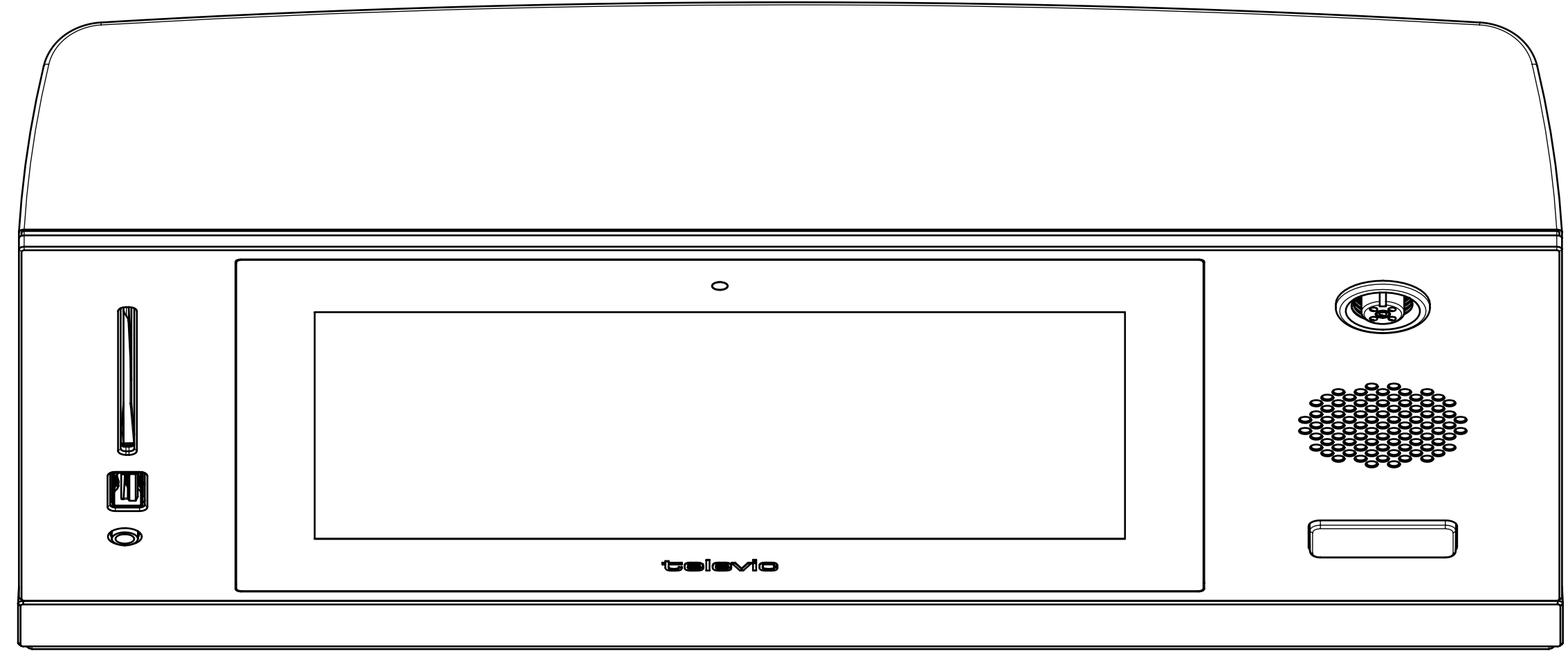
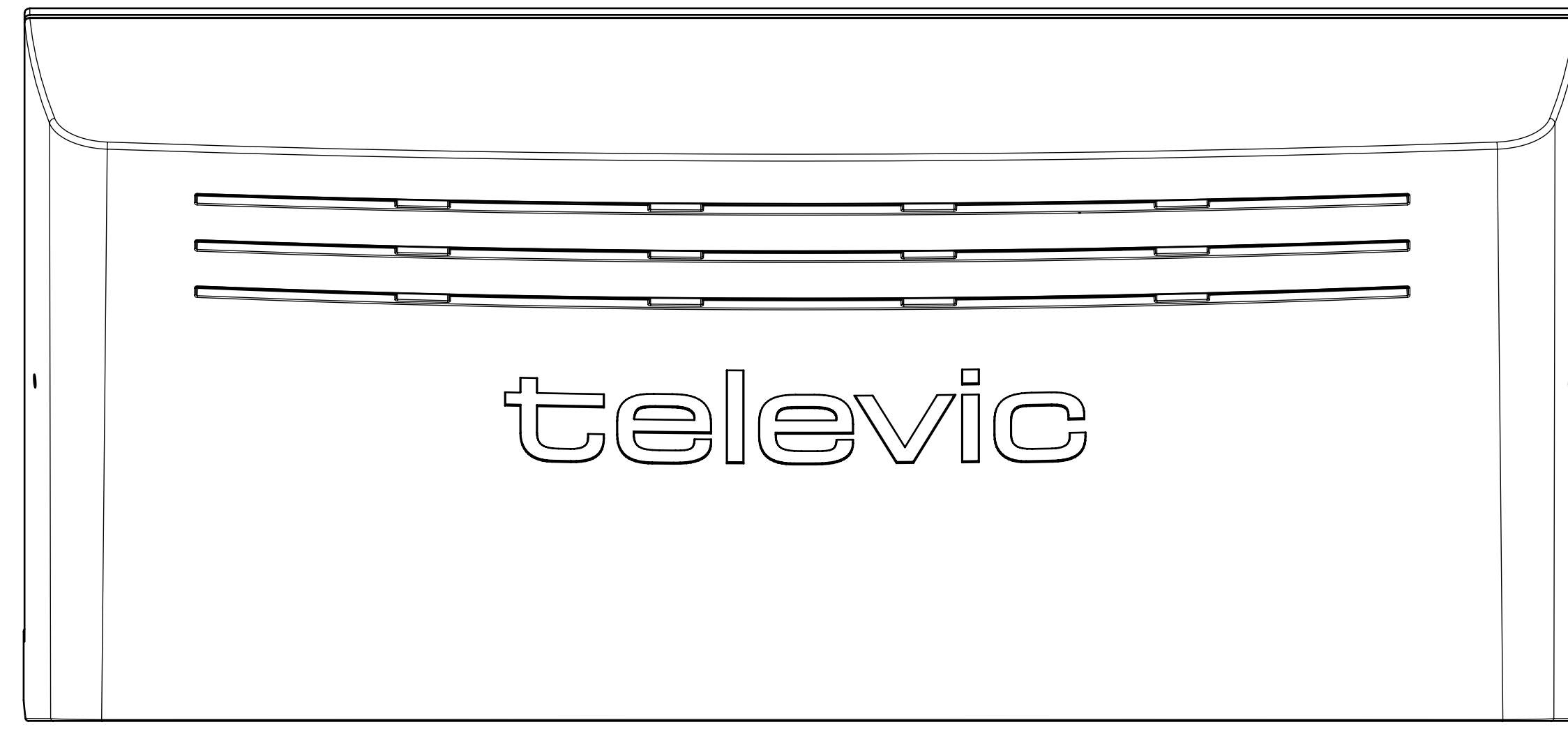
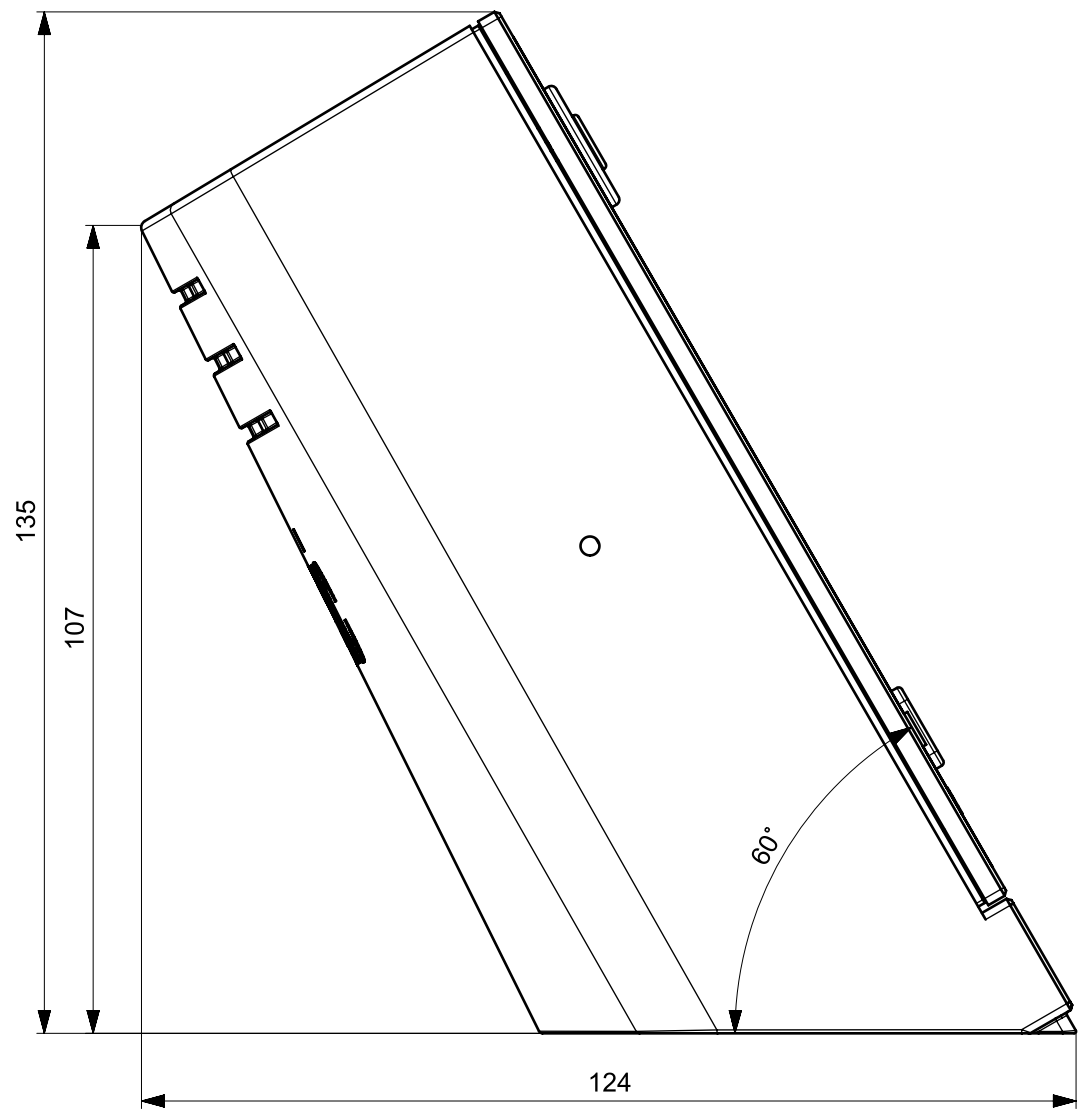
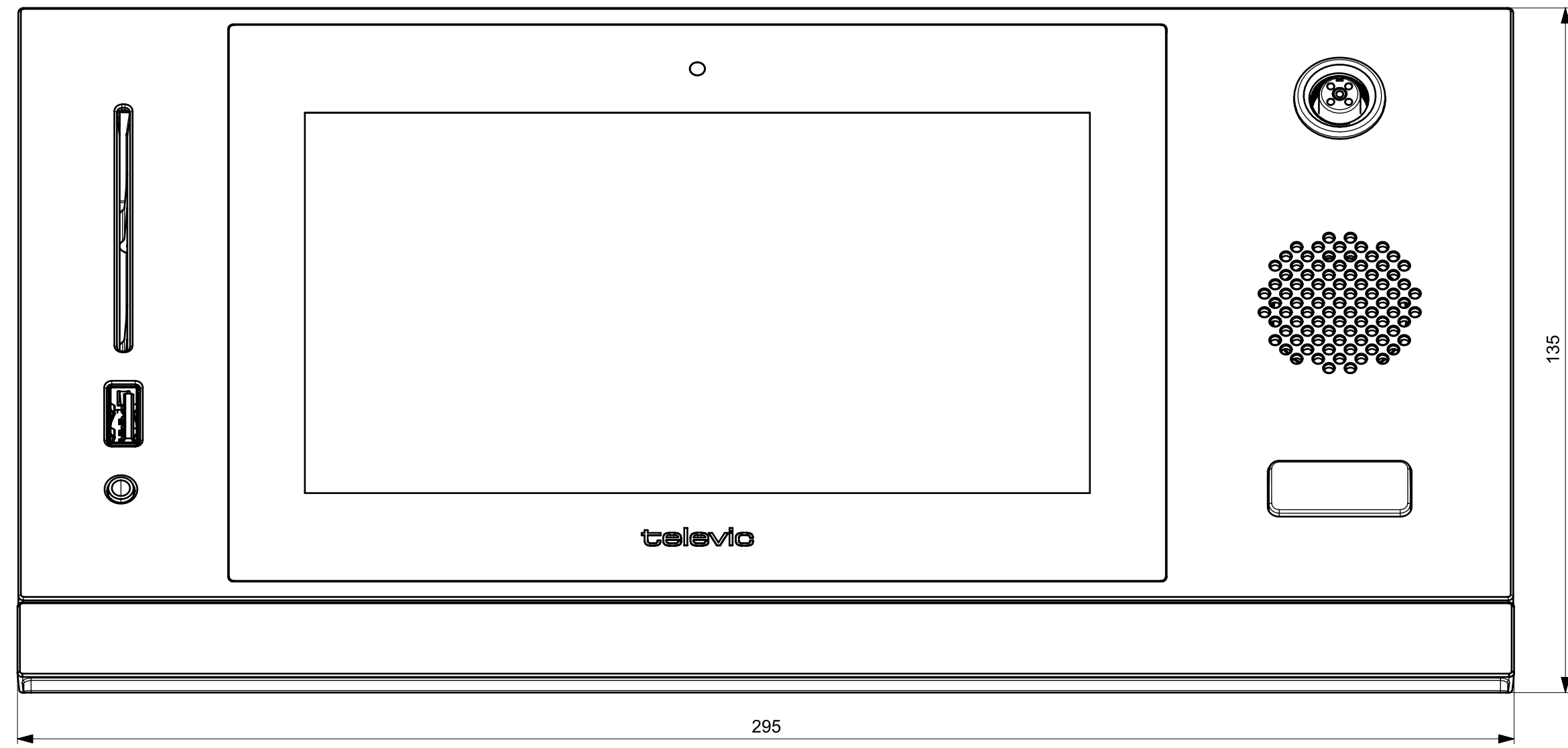

0.01	Original drawing	14.05.12	Luigi
Revision	ECO-1	Revisions - description	Date
Linear tolerances	Surface roughness	Shape and position tolerances	Form tolerances
ISO 2768-mS	ISO 1302	ISO 1101 / ISO 2194 - K	ISO 2768-mS
Drawing name			Material
uniCOS 7" + Bracket 7" PC/ABS PLIXUS MM FM			See separate parts
Drawn by	Scale	Drawing number	Sheet
71.82.2012_M07_0.01	1:1	71.82.2012_M07_0.01	1 of 1
Approved by	Scale	Sheet	Formal
	1:1	1 of 1	A0

televic CONFERENCE