

- Remarks
- * material :
 - fltp: steel E=2mm
 - cover: hot dip galvanized steel E=0.75mm
 - * painting : powder coating
 - Tiger coating Carbon 01 light structured 80µm (±30µm)
 - * screening : Pantone 421C
 - General dimensions : 250 x 80mm R5
 - Cutout dimensions: 235 x 75 mm R5
 - Build in depth: 70mm
- Price applied to the specified quantity.

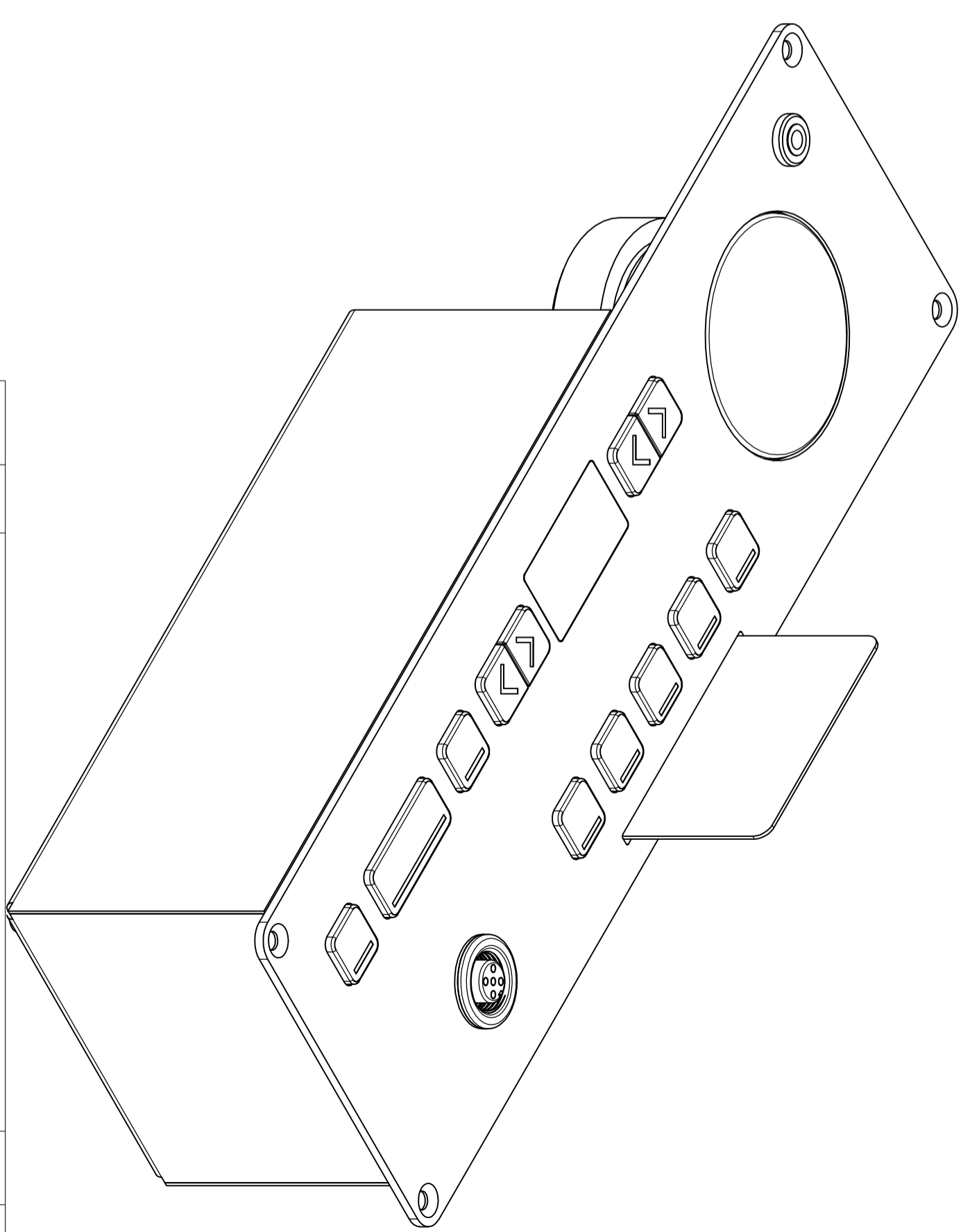
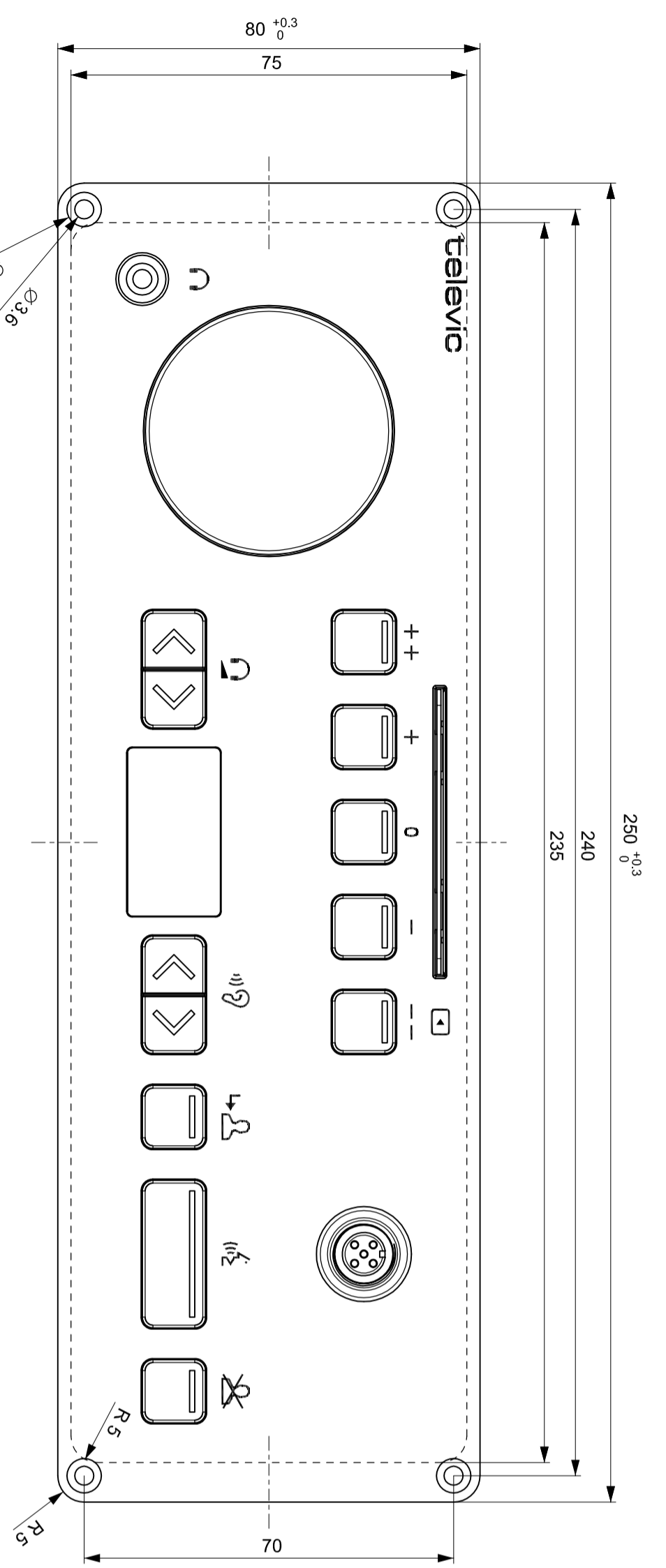

1.02		hds for SLX connector changed	25/09/2015	SPL
1.01		labeled drawing	21/05/2015	SPL
Revision	ECHvr	Remarks - description	Date	Name
Linear tolerances	Surface roughness	Shape and positioning tolerances	Bend tolerances	Finishing
ISO 2768-ndk	ISO 1302	ISO 1101 / ISO 2768 -K	ISO 2768-ndk	see remarks
Drawing name				Material
				see remarks

CONFIDEA F-CIV

Name	Date	Drawing number	Sheet
SOL	25/09/2015	71.98.0514_M07_2D_1.02	1 of 1
Drawn by	zho2015		Scale
APPROVE DATE APPROV			1 : 1
D. BY	ED	unit : MM	Format
			A2



All rights reserved. No parts of this concept may be reproduced in any form or by any means without the prior written permission of Televic.